



ULTRAFAST SWITCHING RECTIFIER



VOLTAGE - 50 to 800 Volts CURRENT - 10.0 Amperes

FEATURES

- Plastic package has Underwriters Laboratory Flammability Classification 94V-0 Utilizing Flame Retardant Epoxy Molding Compound
- Exceeds environmental standards of MIL-S-19500/228
- Low power loss, high efficiency
- Low forward voltage, high current capability
- High surge capacity
- Ultra Fast recovery times, high voltage
- High temperature soldering : 260°C / 10 seconds at terminals
- Pb free product at available : 99% Sn above meet RoHS environment substance directive request

MECHANICAL DATA

- Case: ITO-220AC
- Terminals: Lead solderable per MIL-STD-202, Method 208
- Polarity: As marked
- Mounting Position: Any
- Weight: 0.08 ounce, 2.26 gram

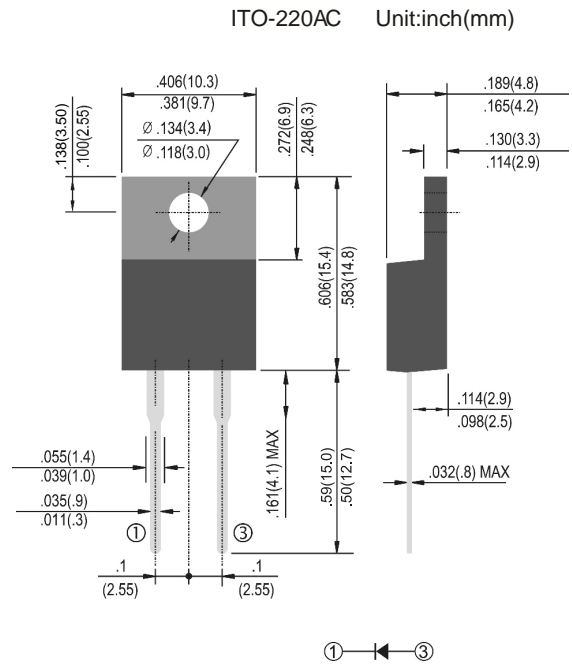

MAXIMUM RATINGS AND ELECTRICAL CHARACTERISTICS

Ratings at 25 °C ambient temperature unless otherwise specified.

Single phase, half wave, 60Hz, resistive or inductive load.

For capacitive load, derate current by 20%

TYPE NUMBER	UF1000F	UF1001F	UF1002F	UF1003F	UF1004F	UF1006F	UF1008F	UNITS
Maximum Recurrent Peak Reverse Voltage	50	100	200	300	400	600	800	V
Maximum RMS Voltage	35	70	140	210	280	420	560	V
Maximum DC Blocking Voltage	50	100	200	300	400	600	800	V
Maximum Average Forward Rectified Current .375" (9.5mm) lead length @ T <sub>c</sub> =100 °C	10							A
Peak Forward Surge Current , 8.3ms single half sine wave superimposed on rated load(JEDEC method)	150							A
Maximum Instantaneous Forward Voltage at 10.0A	1.0		1.3		1.7			V
Maximum DC Reverse Current @T <sub>A</sub> =25 °C	10.0							μA
at Rated DC Blocking Voltage @T <sub>A</sub> =125 °C	500							
Maximum Reverse Recovery Time(Note 1)	50					75		nS
Typical Junction capacitance (Note 2)	80					50		pF
Typical Junction Resistance (Note 3) R <sub>JA</sub>	15							°C/W
Operating and Storage Temperature Range T <sub>J</sub> ,T <sub>STG</sub>	-55 to +150							°C

NOTES:

1. Reverse Recovery Test Conditions: IF=0.5A, IR=1A, Irr=0.25A
2. Measured at 1 MHz and applied reverse voltage of 4.0 VDC
3. Thermal resistance from junction to ambient and from junction to lead length 0.375"(9.5mm) P.C.B.mounted

# DEVICE CHARACTERISTICS

## UF1000F THRU UF1008F

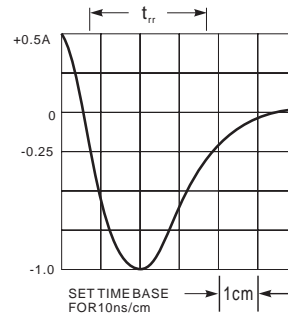
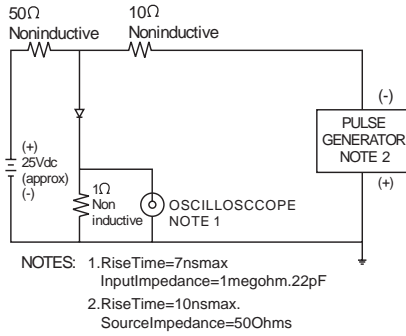

Fig. 1-REVERSE RECOVERY TIME CHARACTERISTIC AND TEST CIRCUIT DIAGRAM

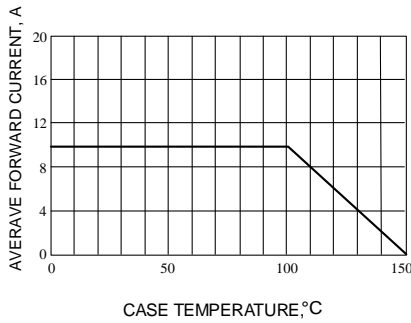

Fig. 1-TYPICAL FORWARD CURRENT DERATING CURVE

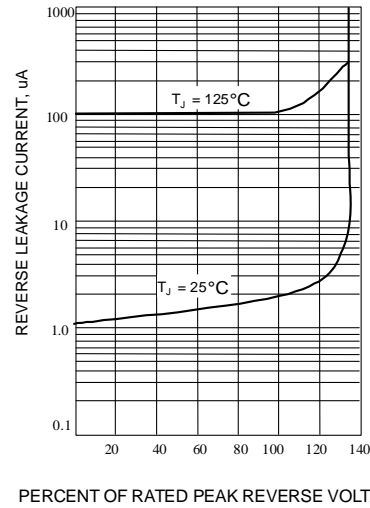

Fig. 2-TYPICAL REVERSE CHARACTERISTICS

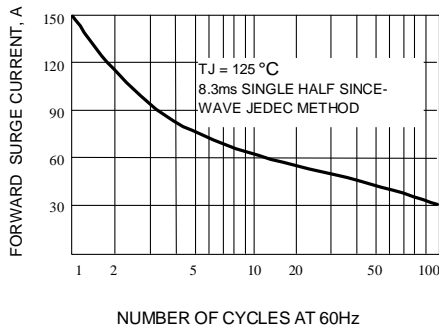

Fig. 3-MAXIMUM NON-REPETITIVE FORWARD SURGE CURRENT

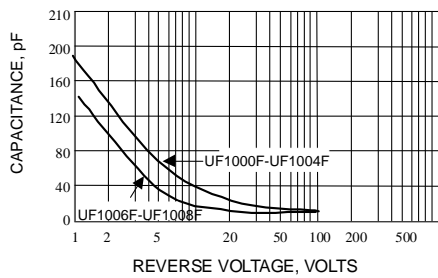

Fig. 4-TYPICAL JUNCTION CAPACITANCE

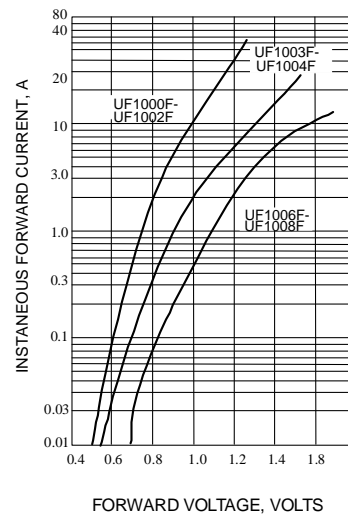

Fig. 5-TYPICAL FORWARD CHARACTERISTICS